

CENTRAL MACHINERY®

AIR FILTER SYSTEM - REMOTE CONTROL

Model 46361

OPERATING INFORMATION

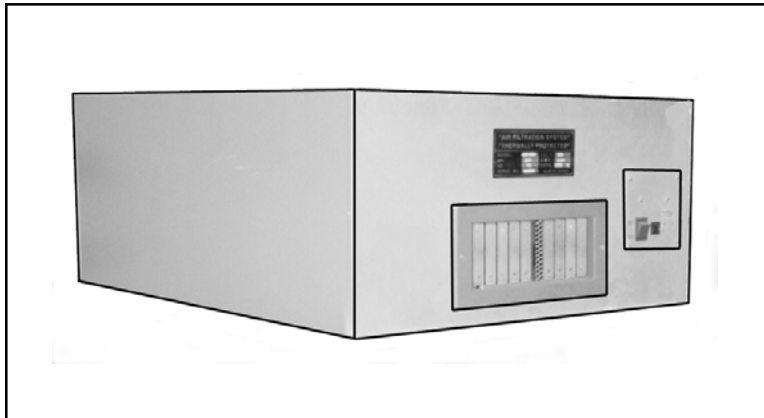

3491 Mission Oaks Blvd., Camarillo, CA 93011
Visit our Web site at <http://www.harborfreight.com>

Copyright© 2001 by Harbor Freight Tools®. All rights reserved. No portion of this manual or any artwork contained herein may be reproduced in any shape or form without the express written consent of Harbor Freight Tools.

For technical questions please call 1-800-444-3353

SPECIFICATIONS TABLE

Item	Description
Electrical Requirements	110V / 2.3 Amps / 275 Watts
Remote Control Electrical Requirements	9 Volt Battery (included)
Remote Control Range	25 Ft.
Capacity	510 Cubic Feet Per Minute
Effective Area	4,000 Cubic Feet
Noise Level	50-60 Decibels
Filter Bag Rating	20 Micron
Overall Dimensions	30" x 24" x 12"
Filter Bag Size	18" x 10" x 7"
Filter Net Size	23-1/2" x 11-3/8"
Fan Diameter	5"
Weight	39.7 Lbs.

SAVE THIS MANUAL

You will need this manual for the safety warnings and precautions, operating and maintenance procedures, parts list and diagram. Keep your invoice with this manual. Write the invoice number on the inside of the front cover. Keep this manual and invoice in a safe and dry place for future reference.

SAFETY WARNINGS AND PRECAUTIONS

1. **KEEP WORK AREA CLEAN AND DRY.** Cluttered, damp or wet work areas invite injuries.
2. **KEEP CHILDREN AWAY FROM WORK AREA.** Do not allow children to handle this product.
3. **STORE IDLE EQUIPMENT.** When not in use, tools and equipment should be stored in a dry location to inhibit rust. Always lock up tools and equipment and keep out of reach of children.
4. **DO NOT USE THIS PRODUCT IF UNDER THE INFLUENCE OF ALCOHOL OR DRUGS.** Read warning labels on prescriptions to determine if your judgement or reflexes are impaired while taking drugs. If there is any doubt, do not attempt to use this product.
5. **INDUSTRIAL APPLICATIONS MUST FOLLOW OSHA REQUIREMENTS.**

6. **CHECK FOR DAMAGED PARTS.** Before using this product, carefully check that the Air Filter System will operate properly and perform its intended function. Check for damaged parts and any other conditions that may affect the operation of this machine. Replace or repair damaged or worn parts immediately.
7. **REPLACEMENT PARTS AND ACCESSORIES.** When servicing, use only identical replacement parts. Only use accessories intended for use with this product. Approved accessories are available from Harbor Freight Tools.
8. **MAINTAIN THIS PRODUCT WITH CARE.** Keep this product clean and dry for better and safer performance.
9. **MAINTENANCE:** For your safety, service and maintenance should be performed regularly by a qualified technician.
10. **USE THE RIGHT PRODUCT FOR THE RIGHT JOB.** There are certain applications for which this product was designed. Do not use small equipment to do the work of larger industrial equipment. Do not use this product for a purpose for which it was not intended.
11. **WARNING:** The warnings, cautions, and instructions discussed in this manual cannot cover all possible conditions and situations that may occur. It must be understood by the operator that common sense and caution are factors which cannot be built into this product, but must be supplied by the operator.

SPECIFIC PRODUCT WARNINGS AND PRECAUTIONS

1. **IF PLACING THE AIR FILTER SYSTEM ON A TABLE OR SHELF, MAKE SURE THE MACHINE IS PLACED SECURELY ON A FLAT, LEVEL, STURDY TABLE OR SHELF CAPABLE OF SUPPORTING THE WEIGHT OF THE MACHINE.**
2. **IF ATTACHING THE AIR FILTER SYSTEM TO A CEILING OR WALL, MAKE SURE THE MACHINE IS ATTACHED SECURELY TO CEILING JOISTS CAPABLE OF SUPPORTING THE WEIGHT OF THE MACHINE.**
3. **ALWAYS DISCONNECT THIS MACHINE FROM ITS ELECTRICAL SUPPLY SOURCE BEFORE PERFORMING ANY SERVICES OR MAINTENANCE.** Make sure to turn off the Air Filter System prior to it being cleaned, replacing the Filter Net (part #1), etcetera.
4. **GROUND THIS MACHINE.** The electrical power cord for this product is equipped with a grounded, 3-prong plug. Make sure this product is always plugged into a grounded, 3-hole electrical receptacle.

5. **MAKE SURE THE POWER SWITCH (part #19) IS IN THE “OFF” POSITION BEFORE PLUGGING IN THE POWER CORD.**
6. **DO NOT ABUSE THE POWER CORD.** Do not yank the Power Cord (part #8) to disconnect it from the electrical receptacle. Do not move this machine with the power cord in the outlet. Keep the cord away from heat, oil, and sharp edges.
7. **IF YOU USE AN EXTENSION CORD, MAKE SURE TO USE ONLY UL APPROVED CORDS HAVING THE CORRECT GAUGE AND LENGTH. (SEE FIGURE A.)**

REQUIRED EXTENSION CORD GAUGE						
Nameplate Amperes	Extension Cord Length					
	25'	50'	75'	100'	150'	200'
0 - 5	16	16	16	14	12	12
5.1 - 8	16	16	14	12	10	-
8.1 - 12	14	14	12	10	-	-
12.1 - 15	12	12	10	10	-	-
15.1 - 20	10	10	10	-	-	-

FIGURE A

8. **KEEP THE FILTER NET (part #1) AND FILTER BAG (part #2) CLEAN, IN PLACE, AND IN WORKING ORDER.**
9. **DO NOT PUT ANY OBJECT(S) INTO THE VENTILATION OPENINGS.**
10. **MAINTAIN A SAFE WORK ENVIRONMENT.** Do not use this product in or near damp or wet areas. Do not expose this product to rain. Keep work area well lit. Make sure there is adequate surrounding work space. Use this product in a well ventilated area. Do not operate this product in the presence of flammable liquids, gasses, or dust. To avoid accidental electric shock, do not let your body come in contact with grounded surfaces such as pipes, radiators, ranges, etcetera.
11. **WARNING:** People with pacemakers should consult with their physician(s) before using this product. Operation of equipment in close proximity to a heart pacemaker could cause interference or failure of the pacemaker. (*California Health & Safety Code 25249.5, et seq.*)
12. **WARNING:** This product contains or, when used, produces a chemical known to the State of California to cause cancer and birth defects or other reproductive harm. (*California Health & Safety Code 25249.5, et seq.*)

UNPACKING

When unpacking, check to make sure all parts shown on the Parts List (page 11) are included. If any parts are missing or broken, please call Harbor Freight Tools at the number shown on the cover of this manual as soon as possible.

ASSEMBLY AND OPERATING INSTRUCTIONS

NOTE: All parts listed below refer to the parts listed and shown on pages 10 and 11 of this manual.

Placement Of The Air Filter System:

1. **Caution:** Make sure the Air Filter System is unplugged from its electrical supply source before moving or placing the machine in a particular location.
2. **Caution:** If placing the Air Filter System on a table or shelf, make sure the machine is placed securely on a flat, level, sturdy table or shelf capable of supporting the weight of the machine.
3. **Caution:** If attaching the Air Filter System to a ceiling, make sure the machine is attached securely to ceiling joists capable of supporting the weight of the machine.
4. To attach the Air Filter System to a ceiling; locate the four Hangers (part #31) that are threaded into the four Nuts (#32) attached to the top edges of the machine. (See Figure B, and Assy. Diagram.)

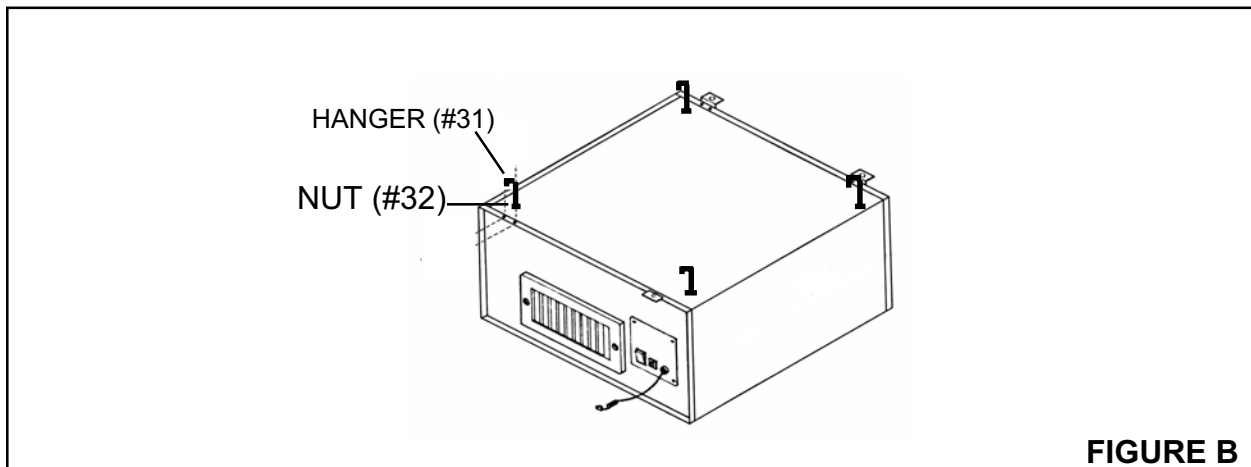

5. Locate the desired ceiling location, and ceiling joists, upon which to attach the Air Filter System.
6. With assistance and proper lifting equipment (not provided), raise the Air Filter System to the desired ceiling location. **Caution:** Make sure all other people are kept *well clear* of the surrounding area during this procedure.
7. Align the four Hangers (part #31) with the ceiling joists and measure for eyelet bolt location. Then insert four eyelet bolts (not included) through the ceiling into the underside of the ceiling joists. Note: Eyelet bolts must be of a size that are capable of safely supporting the weight of the Air Filter System. When hanging the Air Filter System, make sure each Hanger fits completely inside the loop of each eyelet bolt to insure a safe mounting of the Air Filter System. (See Figure C, and Assy. Diagram.)

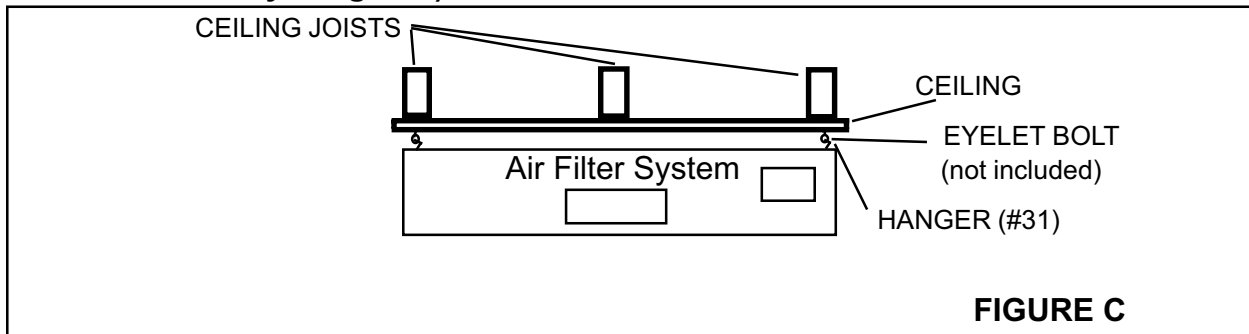

The Manual Power Switch And Remote Control:

1. The Air Filter System is equipped with a manual Power Switch (part #19) and a hand held Remote Control (part #34). (See Figures D, E, and Assy. Diagram.)

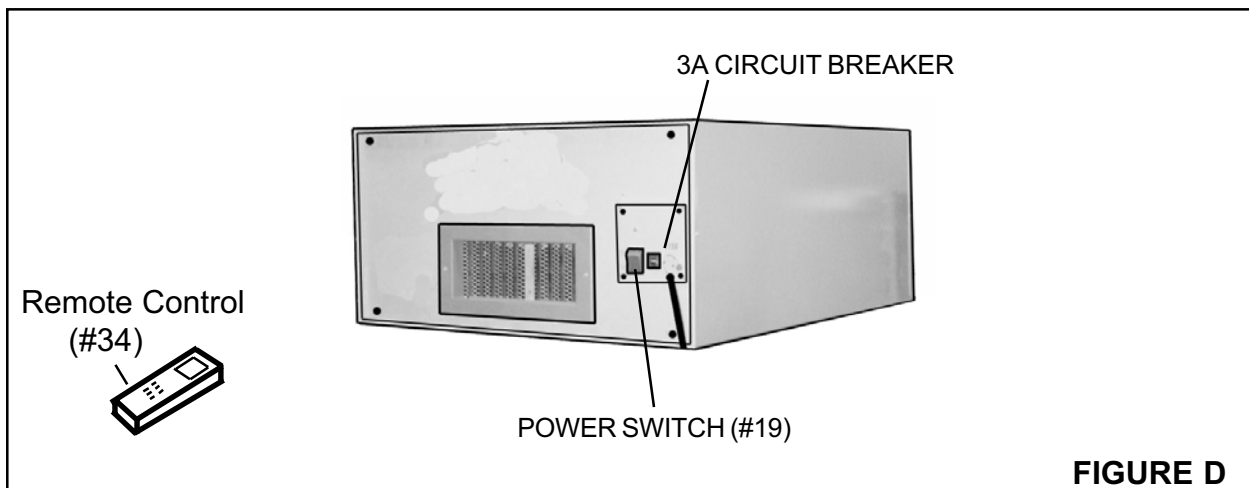

2. When the manual Power Switch (part #19) is turned to its “NON-REMOTE CONTROL” position, the Air Filter System will run continuously until the manual Power Switch is turned to its “REMOTE CONTROL” position. The Air Filter System will then automatically shut off. **(See Figures D, G, and Assy. Diagram.)**
3. The Air Filter System may also be operated by a hand held Remote Control (part #34). The Remote Control has an operating range of up to 25 feet. **(See Figure E, and Assy. Diagram.)**

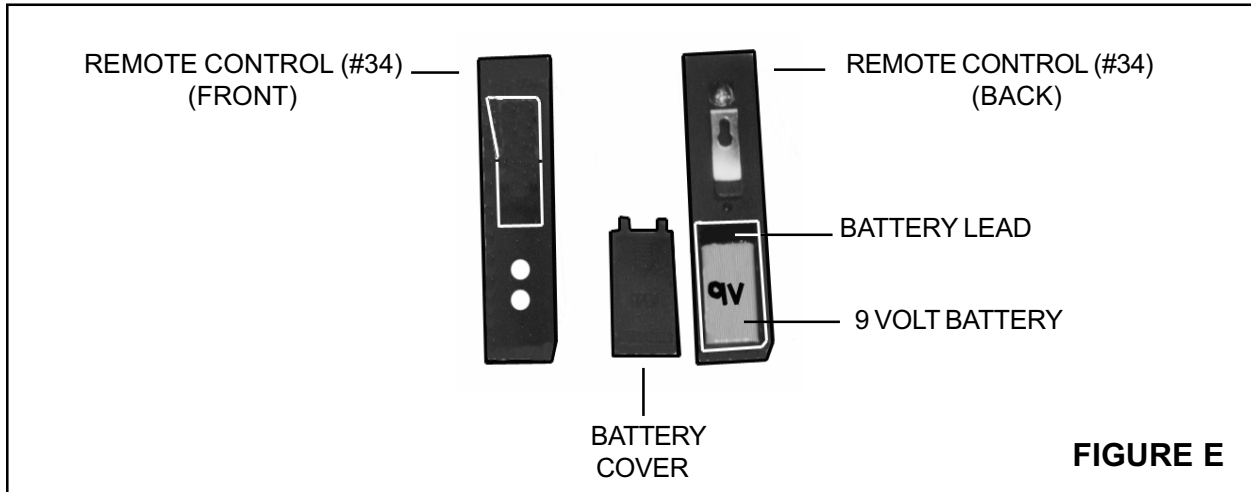

4. **NOTE:** The Remote Control requires a 9 Volt battery. To install a 9 Volt battery in the Remote Control, remove the Battery Cover located on the back of the Remote Control and connect the battery poles to the Battery Lead on the Remote Control. Then, replace the Battery Cover. **(See Figure E, and Assy. Diagram.)**

5. To begin using the Remote Control (part #34) feature, turn the Power Switch (part #19) to its "REMOTE CONTROL" position *and leave it in that position*. Then, to turn the Air Filter System on, press the "ON" button located on the Remote Control. To turn the Air Filter System off, press the "OFF" button located on the Remote Control. **(See Figure E, G, and Assy. Diagram.)**

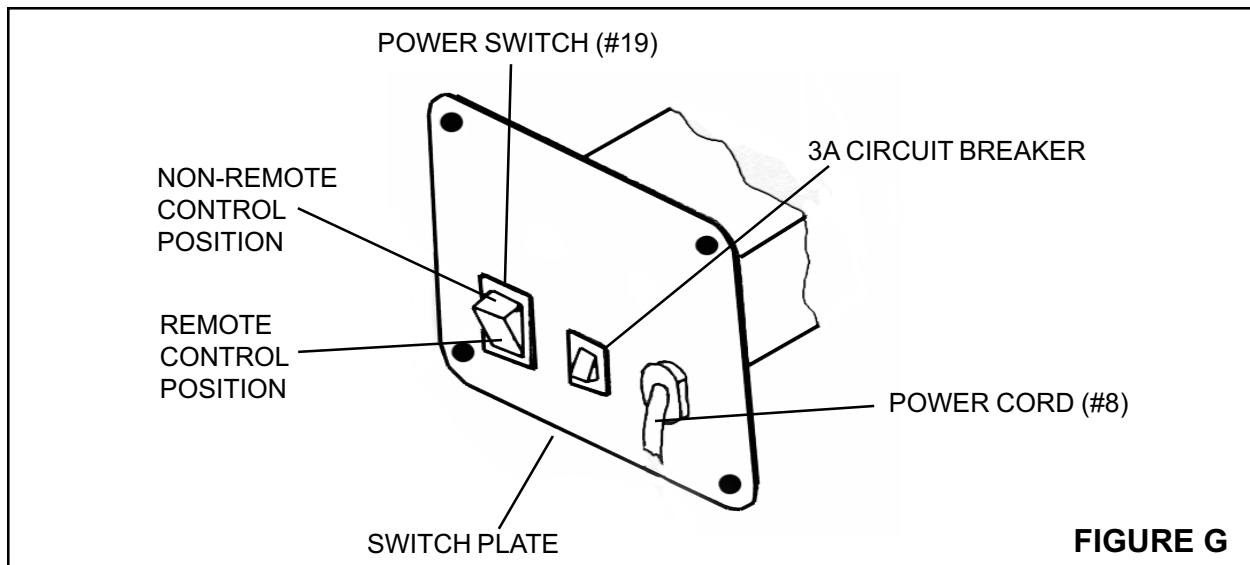

CLEANING AND MAINTENANCE

1. **Caution:** Always disconnect the Air Filter System from its electrical supply source before performing any cleaning, servicing, or maintenance.
2. Before each use, inspect the general condition of the Air Filter System. Check for loose screws, misalignment, binding of moving parts, broken parts, loose or damaged electrical power cord, and any other condition that may affect its safe operation. If abnormal noise or vibration occurs, disconnect the Air Filter System from its electrical supply source immediately and have the problem corrected before further use. Do not use damaged equipment.
3. Periodically, inspect the Filter Net (part #1) for dirt and debris and, if necessary, remove and change the Filter Net. The Filter Net is located at the rear of the Air Filter System unit. To remove the Filter Net, unlock the *two* Clips located on the rear/top and bottom panels of the unit. Then, remove the Filter Net to inspect its condition. Then, replace the old (or new) Filter Net in the rear of the unit and lock it back in place with the two Clips. **(See Figure H.)**

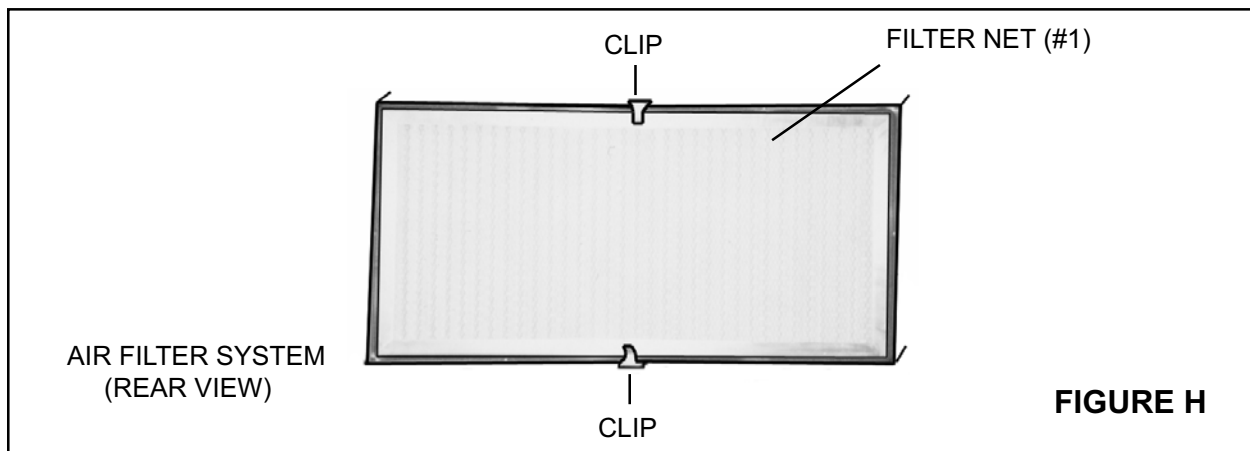

4. Periodically, inspect the Filter Bag (part #2) for dirt and debris and, if necessary, remove and clean the Filter Bag. The Filter Bag is located at the rear of the Air Filter System unit. To remove the Filter Bag, unlock the *two* Clips located on the rear/top and bottom panels of the unit. Remove the Filter Net (part #1). Then, remove the Filter Bag to inspect its condition. If necessary, use compressed air to blow the dirt and debris from the Filter Bag. **Caution:** During this procedure, make sure to wear ANSI approved safety impact glasses, ANSI approved hearing protection, and ANSI approved dust protection. ANSI approved safety impact glasses, ANSI approved hearing protection, and ANSI approved dust protection are available from Harbor Freight Tools. Then, replace the Filter Bag and Filter Net in the rear of the unit and lock them back in place with the two Clips. **(See Figures H, I, and Assy. Diagram.)**

FILTER BAG (#2)

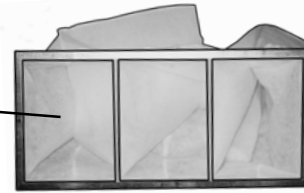

FIGURE I

5. If necessary, wipe the outside of the Air Filter System with a damp cloth. You may use a mild detergent.

PLEASE READ THE FOLLOWING CAREFULLY

THE MANUFACTURER AND/OR DISTRIBUTOR HAS PROVIDED THE PARTS DIAGRAM IN THIS MANUAL AS A REFERENCE TOOL ONLY. NEITHER THE MANUFACTURER NOR DISTRIBUTOR MAKES ANY REPRESENTATION OR WARRANTY OF ANY KIND TO THE BUYER THAT HE OR SHE IS QUALIFIED TO MAKE ANY REPAIRS TO THE PRODUCT OR THAT HE OR SHE IS QUALIFIED TO REPLACE ANY PARTS OF THE PRODUCT. IN FACT, THE MANUFACTURER AND/OR DISTRIBUTOR EXPRESSLY STATES THAT ALL REPAIRS AND PARTS REPLACEMENTS SHOULD BE UNDERTAKEN BY CERTIFIED AND LICENSED TECHNICIANS AND NOT BY THE BUYER. THE BUYER ASSUMES ALL RISK AND LIABILITY ARISING OUT OF HIS OR HER REPAIRS TO THE ORIGINAL PRODUCT OR REPLACEMENT PARTS THERETO, OR ARISING OUT OF HIS OR HER INSTALLATION OF REPLACEMENT PARTS THERETO.

Parts Diagram

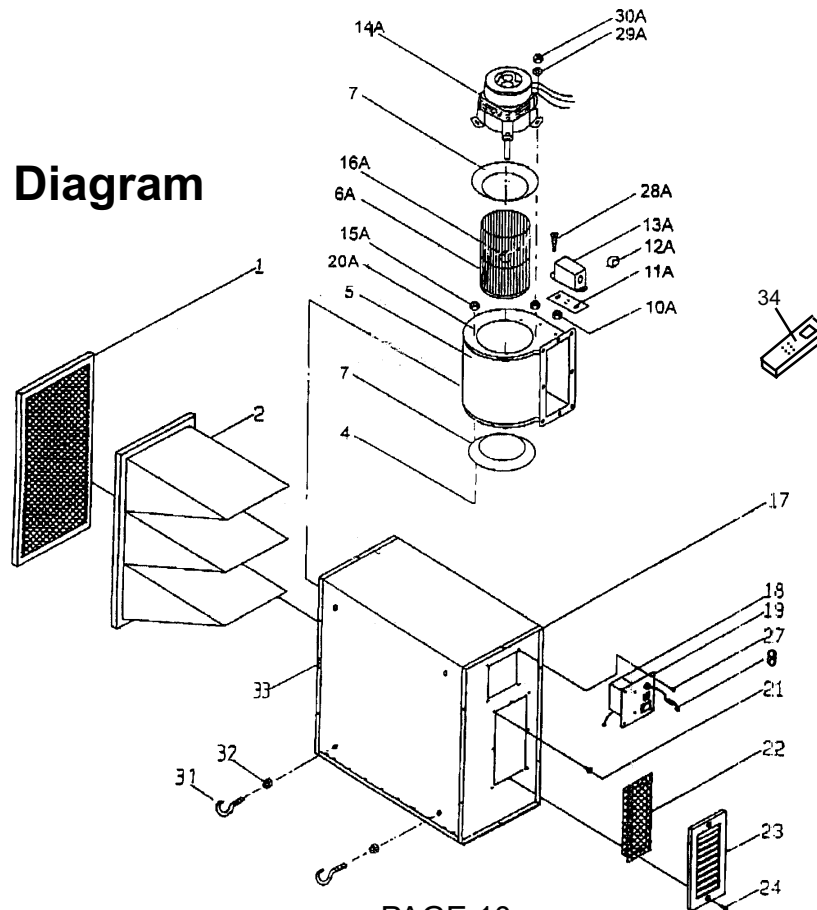

PARTS LIST

NO.	DESCRIPTION	SPECIFICATION	Q'TY
1	FILTER NET		1
2	FILTER BAG		1
4	CROSS HEAD SCREW	M4 x 0.7 x 9	8
5	AIR BOX		1
6A	FAN BLAND	Ø12.7MM	1
7	AIR GUIDE PLATE		2
8	Power Cord		1
10A	NUT	M6	2
11A	CONDENSER FIXED PLATE		1
12A	PG BUSHING		1
13A	CONDENSER COVER		1
14A	MOTOR	Ø 12.7MM	1
15A	SHAKE PROOF BUSHING	Ø 6.5 x 18 x 5	4
16A	SET SCREW	M6 x 8	1
17	MAIN ENGINE BOX		1
18	RECEIVER		1
19	SWITCH		1
20A	ROUND HEAD SCREW	M4 x 20	4
21	HEXAGON FLANGE SCREW	1/4"-20UNC x 1/2"	6
22	SAFETY NET		1
23	OUTLET PORT		1
24	CROSS HEAD SCREW	3/16" -24UNC x 1/2"	2
27	HEXAGON HEAD SCREW	M4 x 0.7 x 9	6
28A	ROUND HEAD SCREW	M5 x 25	2
29A	WASHER	1/4" x 13	4
30A	NUT	M4	4
31	HANGER		4
32	NUT	1/4"	4
33	DOOR CLIP		2
34	REMOTE CONTROL		1

NOTE: Some parts are listed and shown for illustration purposes only, and are not available individually as replacement parts.